

AIM Industrial Inc.



**Your multi-trade industrial
installation and
maintenance contractor.**



Check us out

Replacement of a specialized Dryer Tank at a Food Manufacturing plant in Hamilton, Ontario, Canada.



Contents

About Us

About Us. Our Company. Your Service Provider!	4
Safety and Certifications	6
Multi-Trades and Sectors Serviced	8

Services

Machinery Moving and Installation	9
Millwrighting	10
Rigging and Iron Work	13
Electrical	14
Piping	17
Sheet Metal Fabrication and Installation	18
Heating, Ventilation, Air Conditioning and Refrigeration (HVAC/R)	21
Fabrication	22
Modular Buildings/Pump Skids/Utility Enclosures/Power Centers	25
Automation, Machine Shop and 3D Printing	26
Robotics	29
Automotive	30
Stamping Presses	32
Pharmaceutical, Food and Beverage	33
Plastics and Aluminum	34
Health Care, Educational and Institutional	35
Packaging, Consumer Products and Chemical Plant	36
Cement, Aggregate and Mining	37
Plant Expansion and Relocation	38
Emerging Markets, Hydrogen and Renewable Energy	39

AIM Industrial Inc.  **CHECK OUT OUR WEBSITE**
www.aimindustrial.ca

AIM Industrial Inc. provides everything from plant maintenance and manpower support, to safety upgrades, to complete turnkey process installations, machinery moving, fabrication, expansions and relocations.

About Us. Our Company. Your Service Provider!

■ Incorporated in 2008, AIM Industrial is a Full Service, Multi-Trade contractor with the following in-house services: millwrighting, rigging, iron work, electrical, mechanical, sheet metal, HVAC service contracts, TSSA piping, and fabrication. As specialists in turnkey machinery/equipment installations, maintenance and repairs for numerous business sectors, AIM is here to assist 24/7 - whether it be a small repair job during production hours, or a shutdown turnkey replacement project of a full assembly line. AIM Industrial is a genuinely connected company with great chemistry.

Our growth has been strategic yet constant in order to avoid thin and inconsistent service. Our excellence and success is derived from each and every employee's skill and contribution. We focus on what we do best and have a strong network of skilled, professional and certified support. That has led to AIM Industrial being chosen as Toyota Canada's #1 Rated "General (turnkey) Contractor" spanning majority of years from fiscal 2016 and into 2021, where we met or exceeded expectations on:

Safety, Supervision, Quality, Schedule and Cost.

It takes a true Team effort to achieve such an honorable status. Meeting or Exceeding in those five categories is our Mission Statement to all of our customers. That, is what we are most proud of and these are the benefits your company will be receiving from AIM!

A company is only as strong as the Team which, includes its' Leadership. The AIM Team, with its vast years of combined experience, is always here to help.

100%

Focused on Customer satisfaction, complete trade coverage and continual improvement as we move into the future.



Electrical



Piping



HVAC/R



Sheet Metal



Our Services



Millwrighting



Rigging



Fabrication



Machining

“

We have been working with AIM Industrial for about 7 years now. During that time, we have found them to be a very professional company and extremely accommodating. They have high quality employees and will continue to be our main resource for Maintenance Support, Fabrication and Electrical Contracting.

Our experience with AIM has been outstanding. They're dependable and we get excellent service consistently. They've been a great long-term resource and are very supportive of our needs. It would be much more difficult to meet our customers' needs if we didn't have AIM as a partner.

We have seen a significant decrease in downtime since we started utilizing AIM for Maintenance and Electrical needs. In our bakery, we have kept our downtime to a minimum due to your staff always answering the call and going beyond the call of duty, at all hours of the day and night. We have machines in our facility that cost thousands of dollars an hour in production input when they are down, therefore, AIM is not only the first place we call, they are the ONLY place we call to get our equipment back up and running quickly.

- Major Food Manufacturing plant in Brantford

”

AIM is well positioned to deliver its commitment to customer satisfaction, complete trade coverage and continual improvement as we move into the future.

We currently have over 200 certified tradespeople with a fleet of over 50 equipped service vehicles. Our facility is centrally located in Cambridge, consisting of 80,000 square feet of building including: an in-house sheet metal

fabrication shop, a custom miscellaneous metals fabrication shop, a pipe fabrication shop, an equipment assembly shop, sales shop, a custom machine shop, a tool & equipment shop, and an in-house vehicle repair shop.

We look forward to working with you on any future project of any size...from large to small in scope. Let us know if you require our trades rates or would like a quotation on any upcoming work.



29 Cherry Blossom Rd. Cambridge, ON, N3H 4R7
(519) 747-2255 - www.aimindustrial.ca - info@aimindustrial.ca

Safety and Certifications

■ Safety is our top priority. We have a dedicated IHSA certified trainer on staff. We provide job specific risk assessments and safe work plans. Our trades people are all fully trained to meet the needs of today's industrial leaders. AIM is a fully insured company with WSIB, private liability insurance, and bonding capabilities.



AIM Industrial Inc. was awarded Toyota Canada's prestigious "Supplier Award of Excellence" for fiscal 2015, 2016, 2017, 2019 and 2020.

AIM achieved this #1 rating through a Toyota Performance Report which bases the score on the following five categories:

Safety, Schedule, Supervision, Quality and Cost.



AIM Industrial Inc. scored "Meeting" or "Exceeding" in every single category. We are very proud of this as it truly reflects the strength and dedication of our Team. AIM extends this same level of service to any and all of our customers—regardless of industry!

Additional Training and Certifications:

AIM Industrial trades people are certified in their respective trades and have additional training and certifications such as:

- COR Applicant
- WHMIS
- GE Gas Turbine Training
- Working at Heights
- Rigging Certification
- Confined Space
- First Aid Training
- Elevated Work Platform
- ARC Flash Training
- Crane Operation
- AMP Certification
- Forklift Operation
- Cognibox Certification
- Fire Watch Training
- STOP Training
- IHSA Supervisor Training
- BROWZ Certified
- ISNetworld Certified
- Ariba Supply

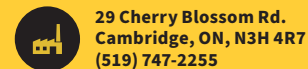
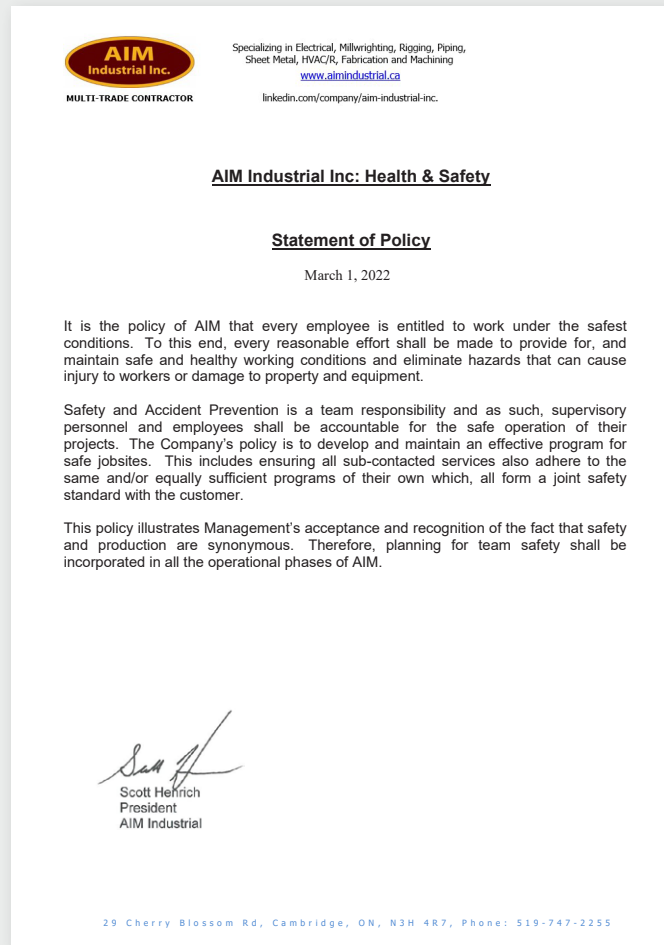

Multi-Trades and Sectors Serviced

AIM is a Multi-Trade Industrial Contractor servicing Southwestern Ontario



Industries Served:

Included but not limited to

- Food, Beverage and Packaging
- Pet Food
- Automotive
- Consumer Products
- Chemical and Rubber
- Water/Waste Water Management
- Renewable Energy, Hydrogen, and Emerging Markets
- Steel Mill
- Cement and Aggregate
- Fabric and Textiles
- Recycling
- Pharmaceutical and Healthcare
- Plastics and Aluminum
- Stamping, Injection Molds and Extrusion
- Presses
- Manufacturing/Assembly plants
- Institutional/Educational/Public Services
- Overhead crane repairs
- Solar
- Robotics
- OEM (Original Equipment Manufacturer)

Services Offered:

- Millwrighting
- Rigging
- Iron Work
- Electrical
- Sheet Metal
- Automation
- Piping/Mechanical
 - a. TSSA
 - b. Gas and Refrigeration
 - c. Process Piping
- HVAC Service, Installation and Support
- Fabrication (CWB)
 - a. Custom design
 - b. Carbon, Stainless
 - c. Aluminum
- Machine Shop



29 CHERRY BLOSSOM RD.
CAMBRIDGE, ON, N3H 4R7
(519) 747-2255
INFO@AIMINDUSTRIAL.CA

www.aimindustrial.ca

Machinery Moving, and Installation Services

Services

- Turnkey disassembly, relocation, re-installation, and commissioning of process and equipment lines.
- Complete plant and equipment relocations and turnkey installations
- Turnkey Sheet Metal and HVAC/R fabrication, upgrades, installation and servicing of ventilation systems
- Electrical facility and Service upgrades, retrofitting, and expansions
- Robotic installations
- Solar panel installations
- Piping retrofits and upgrades
- Logistics, cross-border support and management



29 CHERRY BLOSSOM RD.
CAMBRIDGE, ON, N3H 4R7
(519) 747-2255
INFO@AIMINDUSTRIAL.CA



24/7 EMERGENCY SUPPORT SERVICE
519.747.2255

Millwrighting Services

The Millwrighting Team has the capability, expertise and equipment required to safely complete plant relocations, equipment re-builds, upgrades, maintenance, repairs, and also workforce support for when you need a few more people

We own the common and specialized equipment required to handle all of your heavy equipment moves in a safe, efficient and competitive manner.

Our depth of technical expertise in the industrial manufacturing market and process industries allows us to complete projects safely and professionally within schedule and budget. We offer reliable and prompt breakdown and maintenance service 24 hours a day, 7 days a week with our experienced, qualified tradespeople supported by a service related management team.

Services

- Process line and equipment maintenance, repair, upgrades, additions, turnkey installations
- Maintenance and vacation labour support
- Specializing in Food, Beverage and Pharmaceutical process equipment installation and maintenance.
- Complete plant relocations, decommissioning and demolition
- Presses: stamping, injection mold, thermoforming, extruder installation, maintenance, break-down service and relocation
- Conveyor installation, repair and upgrades
- Precision alignment and leveling
- Safety guarding fabrication, installation and modification
- Robot turnkey installation and maintenance
- Machinery moving, off-loading and placement
- Specialized and heavy rigging
- Specialized transport
- Crane work
- Skidding and packaging
- Oversized fork-truck supply and operation
- PSHSR

Here AIM Industrial performs a turnkey installation of a 2400 Ton Injection Mold Machine at a Tier 2 Automotive Manufacturer near London, Ontario.



Trouble-shooting a process line in Food manufacturing.



29 CHERRY BLOSSOM RD.
CAMBRIDGE, ON, N3H 4R7
(519) 747-2255
INFO@AIMINDUSTRIAL.CA



Check us out





AIM Industrial offers professional and certified Rigging Tradespeople for your rigging and installation requirements such as this Data Centre in Toronto, Ontario.

www.aimindustrial.ca

Rigging and Iron Work Services

Riggers and Iron Workers take a certain type of tradesperson who understands physics and is able to plan for the adverse surroundings and climate. Safety as always, is paramount to a successful job being done.

The Riggers and Iron Workers of AIM Industrial have decades of experience and knowledge to take your project from concept and engineering, to fabrication and installation.

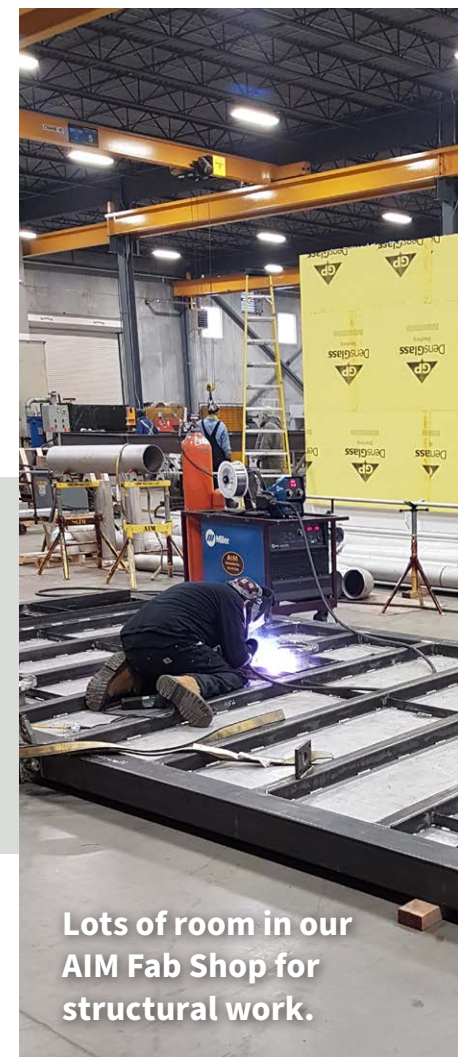

Lots of room in our AIM Fab Shop for structural work.

Services

- Miscellaneous Metals fabrication and installation for any type of company including, but not limited to: Commercial, Industrial, Educational, Food and Beverage, Healthcare, Packaging, Chemical, WWTP, Cement and Aggregate
- Structural reinforcing including facility roofs
- Steel erection
- In-plant mezzanine, catwalk, stair and handrail installation
- Well-experienced in specialized installations such as commercial buildings with unique designs
- Complete plant and equipment relocations with turnkey installations
- Maintenance coverage and assistance



29 CHERRY BLOSSOM RD.
CAMBRIDGE, ON, N3H 4R7
(519) 747-2255
INFO@AIMINDUSTRIAL.CA



24/7 EMERGENCY
SUPPORT SERVICE
519.747.2255

Electrical Services

Our electrical group specializes in construction, service, maintenance, and design. We have decades of experience in all sectors of the electrical industry.

We offer breakdown service 24 hours a day, 7 days a week in both the electrical and electronic areas. Our service tradespeople come with vehicles fully stocked with materials and the tools required to get your production up and running quickly and efficiently. We are backed by a management team with an incredible trade background.

Services

- ESA Certified
- Process Electrical installations
- Industrial Design/Build – Industrial control systems
- Process controls – Automation Integration
- PLC Wiring and Troubleshooting
- Belden Certified for Ethernet
- Instrumentation and instrument calibration
- Electronic/Electrical troubleshooting and repairs
- Preventative Maintenance Programs
- Robotic wiring and installations
- Complete plant/equipment relocations and turnkey installations
- Solar panel installations
- Panel wiring
- Building distribution
- Service installations
- Medium and High Voltage installation and repair
- Variable Frequency Drives (AC & DC drives)
- Facility lighting systems
- Fire alarm systems
- Heat trace
- Grounding
- Machinery and equipment wiring
- Maintenance coverage & assistance
- Hazardous location installation
- Power quality metering and power factor analysis
- Thermal Imaging

Arc-Flash training and equipment are a standard with our Electricians.



29 CHERRY BLOSSOM RD.
CAMBRIDGE, ON, N3H 4R7
(519) 747-2255
INFO@AIMINDUSTRIAL.CA



Check us out



Installation of conduits, cable and cable trays for this high temperature process line at a manufacturing plant near Brantford, Ontario.



Installation of all valves and piping (carbon and stainless) plus mixing and storage tanks for a \$9,000,000 AIM project at a customer's Manufacturing Plant near Toronto, Ontario.

www.aimindustrial.ca

Piping Services

The process-piping, plumbing and pressure welding group specializes in industrial, commercial and institutional installations, repairs, and retrofits of equipment and process systems.

With our experienced and certified tradespeople we are well-trained for various types of welding and are able to assist your company with most piping jobs from small repair and maintenance work to multi-million dollar retrofits or installations, such as the project shown on the left side here.

Services

- TSSA registered
- Process piping - low and high pressure
- Industrial Furnace installation, rebuilds and maintenance
- Boiler and Burner installation, rebuilds and maintenance
- Commercial and Institutional complete mechanical installations
- Pipe Skid design and fabrication
- Large and small bore pipe pre-fabrications and installations
- Steam and Thermal Fluid piping and Boiler installations
- Stainless steel piping and tubing as well as food-grade sanitary piping
- Natural Gas and Propane Piping and installations
- Medical Gas Piping and Process Gas installations
- Hydraulic & Pneumatic Piping and controls
- Aquatherm piping - Certified Installer
- Machinery rebuilds, including presses, injection molding and extruder machines
- Industrial Maintenance
- Refrigeration
- Pipe insulation
- Design build installations
- Plant Maintenance, labour supplement and shutdown assistance
- Backflow services
- HVAC service, installations and support



Fine-tuning the piping in an AIM Fabricated Cooling Tower at our shop



29 CHERRY BLOSSOM RD.
CAMBRIDGE, ON, N3H 4R7
(519) 747-2255
INFO@AIMINDUSTRIAL.CA



24/7 EMERGENCY
SUPPORT SERVICE
519.747.2255

Custom fabrication including sheet metal and electrical in our AIM Fab Shop

www.aimindustrial.ca

Sheet Metal Fabrication and Installation Services

The AIM Sheet Metal Group is set up to service industrial, commercial and institutional companies. Our expertise ranges from custom-design ducting systems, to chutes for the food industry, to educational upgrades, to guards for safety requirements to heavy cement manufacturing, and more. We also offer ventilation design & installation, breakdown service and HVAC/R support.

The Sheet Metal Group consists of fully qualified and certified estimators, coordinators and tradespeople. To compliment its Sheet Metal installation services, the Sheet Metal group is part of a 60,000 square foot well equipped fabrication & paint shop capable of handling all aspects of sheet metal fabrication.

Services

- Building ventilation upgrades
- Custom Design Duct and Sheet Metal Fabrication/Installation
- Industrial Oven Fabrication and Installation
- Fume Extraction System Design, Fabrication and Installation
- Custom Machine and Safety Guarding Design, Fabrication and Installation
- Dust and Material Handling System Design, Fabrication and Installation
- Stack Design, Fabrication and Installation
- Design Build Air Handling Systems
- Spray Booth Design, Fabrication and Installation
- High Definition Plasma Cutting and Plate Forming



29 CHERRY BLOSSOM RD.
CAMBRIDGE, ON, N3H 4R7
(519) 747-2255
INFO@AIMINDUSTRIAL.CA



Check us out

Large cranes were brought by AIM to reach and install a series of new rooftop units at a Food Manufacturer in Toronto, Ontario.





Rooftop AHU, A/C, Make-up air units, and Condensers seen here are professionally installed and maintained by AIM Industrials certified HVAC/R and Sheet Metal tradespeople.

www.aimindustrial.ca

Heating, Ventilation, Air Conditioning and Refrigeration (HVAC/R) Services

Set up to service our industrial, commercial and institutional customers, the HVAC/R teams' expertise ranges from turnkey installations to upgrades of your facility air systems. We offer preventative maintenance packages, ventilation design and installation, breakdown service and HVAC/R system analysis. AIM has a long-standing history of maintaining Ventilation and HVAC Systems at the likes of: Property Management, Insurance, Food and Beverage, and various other publicly occupied companies.

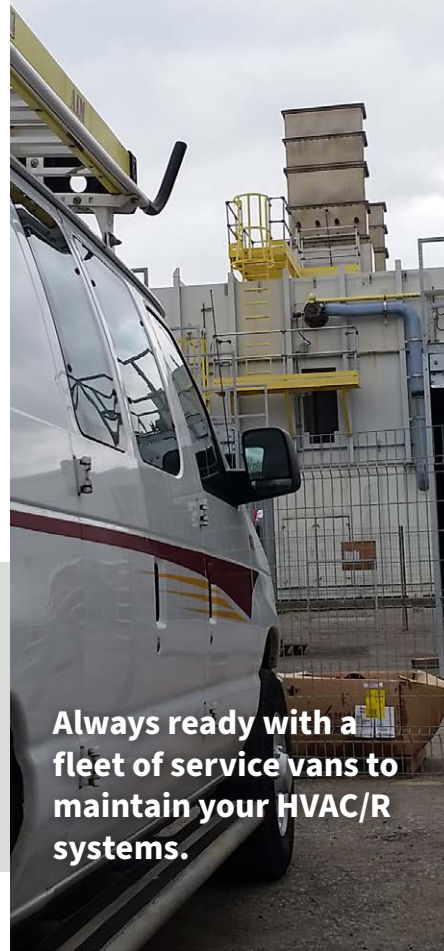

Always ready with a fleet of service vans to maintain your HVAC/R systems.

Services

- HVAC/R service, installations and support
- HVAC/R service contracts
- Facility preventative maintenance
- Plumbing, installations and repairs
- Combustion analysis, support and trouble-shooting
- Electrical service and installations
- Refrigeration installations and repairs
- Chiller maintenance, repairs and support
- Boiler service and repairs
- Cooling towers
- Heating units
- Compressors
- Condensers



29 CHERRY BLOSSOM RD.
CAMBRIDGE, ON, N3H 4R7
(519) 747-2255
INFO@AIMINDUSTRIAL.CA



24/7 EMERGENCY
SUPPORT SERVICE
519.747.2255

Fabrication Services

AIM Industrial's CWB certified fabrication shop operates out of a 40,000 square foot four-bay facility, fully equipped with four overhead cranes and plenty of new fabrication equipment including a brand new Ermaksan plasma table. We work with AutoCAD, SolidWorks, Master-CAM, Key Creator, and are able to accept numerous other files.

Our CWB certifications reflects AIM's standards and skill sets for Carbon and Stainless Steel Welding. Our capabilities include various welding methods including mig, tig, flux-core & stick. We are more than happy to quote your tender package and our fitterwelders are more than capable of transforming your drawings into reality.

Services

- Custom design and fabrication
- Carbon and Stainless steel, aluminum
- Miscellaneous Metals: platforms, mezzanines, stairs, handrail, and more.
- Piping, Mechanical, HVAC/R fabrication
- Safety Guarding
- Catwalks, Mezzanines, Stairs
- Custom electrical and light curtains, stands, brackets and supports
- Food industry equipment and machinery
- Conveyors and custom machinery
- Custom chutes and transitions
- Structural
- Pipe skids and cooling towers
- Machine shop
- Custom machining, reverse engineering, prototype design
- Modular building/Power Center design and fabrication
- Breakdown repairs, shutdown coverage
- Jigs and fixtures, machine weldments
- Robot stand fabrication – singular or multiple
- CWB Certified welding

Platform pre-assembly in the AIM Fabrication Shop saves our customer time and money on site



29 CHERRY BLOSSOM RD.
CAMBRIDGE, ON, N3H 4R7
(519) 747-2255
INFO@AIMINDUSTRIAL.CA



Check us out



This Slat Conveyor: AIM designed, fabricated in our shop, and installed for moving cars at a Tier 1 Automotive manufacturer. Broken up into two sections - the total length is 300 ft with a return length of 600ft. Cars will be driven onto this conveyor and transferred through the plant. AIM Industrial trades included: Fabrication, Millwright & Rigging, Electrical and Piping.



The weld-water cooling tower designed, procured and fabricated by AIM, consists of a pre-engineered building with sump system and internal stainless holding tank, 3 main pumps and one recirculation pump, cooling tower (and cooling tower structural steel), along with integrated controls and automation. It is capable of 1600 gallons per minute servicing 340 robots in a weld-shop and maintaining operating temperatures within 8 degrees. The system operates with a dual cell cross-flow cooling tower, complete with a 12,000 gallon stainless tank reservoir and a side stream filtration system. This pre-tested unit was the first of three shipped and installed in Alabama, U.S.A.

www.aimindustrial.ca

Modular Buildings/ Pump Skids/Power Centres

AIM Industrial has the skills and experience to design and fabricate modular plants to meet your specific standards and preferences, including preferred suppliers - providing a customized plant with components that are familiar to your operators and maintenance personnel. Applying our expertise to scale-appropriate solutions for pilot plants and demonstration plants reduces your project cost and schedule as well as promotes reliable operation, easier maintenance, and versatility of your modular system.

Our industry-leading experience and capabilities range from single module turnkey laboratory scale systems to multi-modular small commercial plants. AIM also has extensive experience retrofitting Sea Cans for Modular Process Systems.



Services

- Water Pumping Buildings
- Industrial Process Pump Skids and Cooling Towers
- Modular Buildings for all equipment requirements
- Switch Gear and Power Enclosures
- Engineering and Design
- Equipment Selection and Sourcing
- In-House Construction including Modular Building & Base Frame/Structural Fabrication – CWB Certified
- Onsite Start-up & Commissioning Support
- Ready to work with the customer to achieve local building code compliance
- BAS (Building Automation System) requirements.



29 CHERRY BLOSSOM RD.
CAMBRIDGE, ON, N3H 4R7
(519) 747-2255
INFO@AIMINDUSTRIAL.CA



24/7 EMERGENCY
SUPPORT SERVICE
519.747.2255



www.aimindustrial.ca

Automation, 3D Printing and Machine Shop Services

With today's technology reaching new heights to move greater volumes faster, more cost-effective and safer - Automation, Custom Machining and even 3D printing are all the norm in the manufacturing industry. AIM Industrial's commitment to our customers is that we will assist in every way possible. Our in house Automation and Machining can handle many possibilities. With an excellent network of professionals, we are able to get complimenting support to solve your problems or visions. Our 3D Printing capabilities come with excellent knowledge and training.

Services

- Line synchronization and integration
- Installation & integration of Robotic systems
- Re-tool lines for consolidation of SKU's 3D Printing and rapid prototyping
- Machining and spare parts supply
- 3D Mechanical design and equipment concept generation
- Machine MTTR/Reliability/Spare Parts cost reduction investigations
- Automated tooling from concept to Install and troubleshooting
- Process Jig/fixture design, modification, and manufacturing
- Plant and equipment layouts with creation of 2D/3D file formats

Having AIM Industrial design machinery for automation processes as in this rendered image...

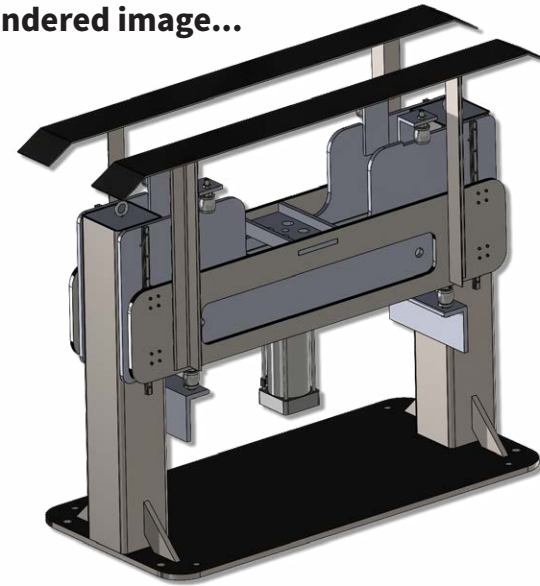

led to AIM fabricating the practical unit shown here: a custom designed pallet-lifter, which...



led to an AIM installed automated pallet lifter tucked inside this outer frame and fully operational at a new state-of-the-art Food Processing plant in London, Ontario.



29 CHERRY BLOSSOM RD.
CAMBRIDGE, ON, N3H 4R7
(519) 747-2255
INFO@AIMINDUSTRIAL.CA



24/7 EMERGENCY
SUPPORT SERVICE
519.747.2255



AIM Industrial is a highly trusted and reputable partner in Robot installation and maintenance.

www.aimindustrial.ca

Robotics Services

Whether it be in Automotive, Food, Packaging, Consumer Products, Plastics, Renewable Energy, the list is endless; Robots are a part of the present and future.

The Tradespeople at AIM Industrial. have decades of combined experience in the Installation, Maintenance and Repair of Robotic machinery and systems.

AIM works with the OEMs, as well as in partnership with a number of Design, Automation and Programming certified companies to ensure your Robotic processes and systems are at peak performance



Robot bases are a standard design and fabrication part of AIM's Fabrication Shop

Services

- Palletizing/De-palletizing
- Machine loading/unloading
- Packaging
- Distribution
- In Process
- End of Line
- Material handling
- Machine tending
- Print and converting
- Roll handling
- Sheet, Pipe and Tube
- Upgrades to Equipment and System Controls
- Gantry Robots
- Articulating Arms
- Cartesian and Multi-Axis Movement and Application Systems



29 CHERRY BLOSSOM RD.
CAMBRIDGE, ON, N3H 4R7
(519) 747-2255
INFO@AIMINDUSTRIAL.CA



24/7 EMERGENCY
SUPPORT SERVICE
519.747.2255

www.aimindustrial.ca

Automotive Services

AIM Industrial's tradespeople, have helped define, not only what a skilled worker is, but also what 24-hour breakdown service means. With an ongoing and growing presence in the Automotive industry, performing trade work from press and conveyor systems, to both paint and weld shops, to team rooms, chiller rooms as well as HVAC/R response - these are the in-house services that have made us into the highly reputable company that we are today.

AIM performs work in ways that has led us to being rated and recognized by Toyota Canada, since 2015, over multiple fiscal years, to be their #1 Rated Supplier in a General Contractor role - able to run complete and turnkey projects where we met or exceeded expectations in numerous categories.

Services

- We have serviced and installed numerous Multi-Trade Turnkey Installations and Relocations related to the industry at facilities such as:
- Multiple Tier Level manufacturers
- Major OEM (Original Equipment Manufacturers)
- On-site satellite office presence
- Our skilled team has experience servicing and installing many types of machinery including:
 - All sizes and styles of Steel Forming and Stamping Presses
 - All sizes of Plastic, Polymer, Aluminum: Injection Mold, Blow and Thermoforming, Extrusion, and other styles of Presses
 - Robotics, Conveyors, Carriage systems, Assembly Lines, Tooling, Weld Shop, Paint Shop, Team Rooms, Superfinishers, Welding Machines, Structural Upgrades, Miscellaneous Metals/Mezzanines, and more...
- Prototype design assistance and manufacturing/fabrication
- Continuously rated among the top contractors for Toyota Canada
- EV Industry re-tooling and MRO
- Labor and vacation support

The Automotive Industry entails large plants with large machinery, moving products along large and long process lines, driven by robotics and automation. Conveyor systems, accessed via service platforms, take products from one end of the plant to the other sometimes crisscrossing each other on the way. Our team works with the customer to ensure a safe and successful installation. Here, the AIM Industrial Iron Working team is shown installing the steel support, fabricated in AIM's Cambridge Shop, at a Tier 1 Automotive plant near Toronto.

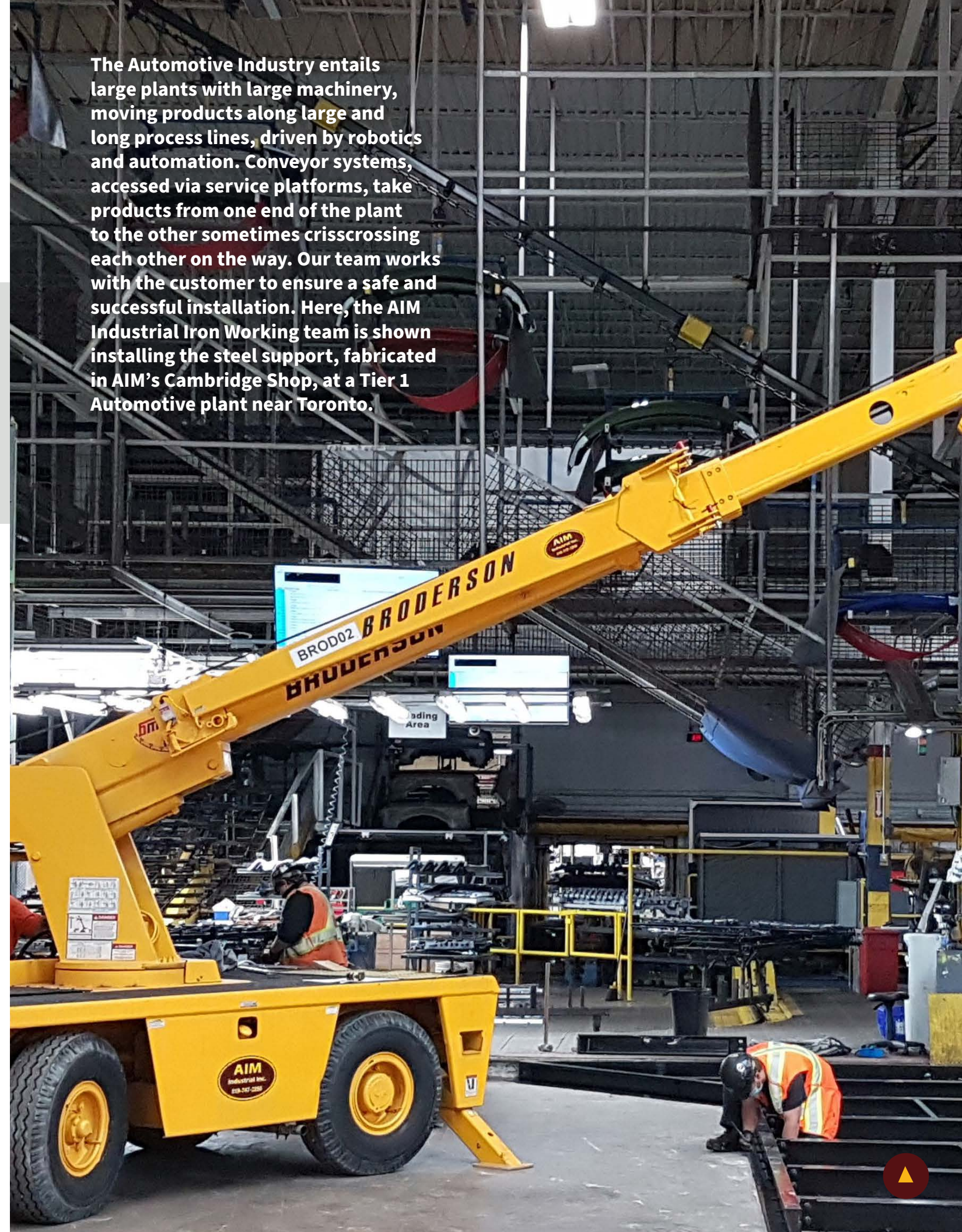

29 CHERRY BLOSSOM RD.
CAMBRIDGE, ON, N3H 4R7
(519) 747-2255
INFO@AIMINDUSTRIAL.CA



Check us out

Stamping Press Services

AIM Industrial, with many employees having over 30 years of being “on the tools”, helps manufacturing companies keep their metal stamping presses running properly for optimal and efficient production. By having a team of expert field service personnel for on-site press repair and product support, you keep your systems running smoother and more cost-productive.

Our field service technicians can work on a wide range of metal forming machinery, whether the machinery was manufactured by AIDA, Komatsu, BLISS, Macrodyne, Eagle or others.

Services

- Rebuild clutches and brakes
- Gib and liner repairs or replacements
- Cushion repairs and replacements
- Pitman arm, plunger repair or replacement
- Main bearing and crank shaft repairs
- Overload protection
- Main gear replacement and press re timing under OEM direction
- Main motor rebuild
- Steel fractures, and cracks on crown body, slide bed and bolsters requiring arc air gouging, welding, stress relieving and machining
- Electrical rewiring, control and safety upgrades, PHSR
- Lubrication system repairs or replacement
- Tie rod replacement
- Hydraulic nut or super nut supply and install
- Rolling bolster rail repairs or supply and install of new
- Press pit flooring precast concrete or stall panel complete with girder supply and install
- Installation of press pits and steel
- Robotics and automated die change system installations
- Stacker, de-stacker, feeder repairs and installations
- Installation of transfer rail systems for multi press stamping operations
- Scrap chute supply, repairs and installations
- Scrap conveyor installation and repair



Check us out

Pharmaceutical, Food and Beverage

AIM Industrial’s skilled tradespeople encompass some of the most experienced workers in the contracting industry – and continue to excel in the Food, Packaging and Pharmaceutical sectors.

From Bakeries to Beverage and Cereals, to Pet Food as well as Poultry/Seafood, to installing and maintaining process systems for the Pharmaceutical industry, AIM Industrial is your Multi-Trade Contractor to help your operations run both efficiently and cost-effectively.

Services

- **Fabrication**
 - Custom fabrication
 - Machine & conveyor guarding
- **Automation Services**
 - Line synchronization and integration
 - Installation & integration of Robotic systems
 - Re-tool lines for consolidation of SKU’s
- **Installation includes, but is not limited to:**
 - Smokehouses, Cookers, Pasteurizers, Ovens
 - Stuffers, Extruders, Coextruders, Injectors
 - Conveying systems
 - Packaging equipment
 - Palletizers/De-palletizers
 - Stainless steel Process & Sanitary Piping
 - Water, Pneumatic, CIP, Vacuum Line installs
 - Complete plant relocations
 - Assembly / Rebuilds/Enhancements of entire lines
- On-Site Repairs & Emergency Service
- Maintenance Coverage
- Plant Maintenance, Labour supplement and Shutdown assistance
- New builds, expansions and relocations
- HVAC service, installations and support

AIM provides ongoing millwright, electrical, mechanical support, along with fabrication, and expansion services at various Food and Packaging Plants in south-central Ontario. AIM supports the following standards, guidance and associations:

HACCP, AIB, GFTC, OABA and CFIA.



29 CHERRY BLOSSOM RD.
CAMBRIDGE, ON, N3H 4R7
(519) 747-2255
INFO@AIMINDUSTRIAL.CA



www.aimindustrial.ca

Plastics and Aluminum Services

Servicing the platen on a large IMM

With today's ever-changing mandates on plastic use leading to retooling of many processes, AIM Industrial is well-positioned to assist your company with Maintenance, Repair and Operations (MRO) of many types of machinery related to both the Plastics and Aluminum industries.

From having installed complete turnkey 2500T Extruder systems, to relocating large Injection Mold Machines for the plastics industry, and then maintaining those systems - our team is here to help keep your production running efficiently and cost effectively.

Turnkey installation by AIM Industrial

Services

- Small to very large Injection Mold Machines (IMMs)
- Various types and sizes of Extrusion Machines
- Thermoforming, Blow Molding, Roto molding, Compounding, and Recycling
- AIM has provided service and/or installed at/for several other Plastics, Aluminum Press and Thermoforming manufacturers such as: UBE/Mitsubishi, Krauss Maffei, JSW, Husky, Van Dorn Demag, Granco Clark, Milacron and more.
- Daily labor support for shift coverage, sickness and vacation support
- Maintenance, Repair, Operations (MRO) support to many customers
- Turnkey demolition, installations and relocation services
- Trouble-shooting
- Re-tooling



Check us out

www.aimindustrial.ca

Health Care, Educational and Institutional Services

During Covid times and since, AIM Industrial has been awarded dozens of upgrade projects for Institutional, Educational and Health Care companies in Southwestern Ontario.

Ranging from motor, chiller and boiler repairs and replacements, to HVAC/R and Ventilation System Upgrades at Universities, High Schools and Junior Schools - at times while school classes were in session - we make it work.

From MRO work such as: motor/pump repairs and replacements to Stainless Steel Pharmaceutical work with the highest safety and cleanliness standards - AIM Industrial's reputation is impeccable and undeniable, even at the level of Heritage Distinction buildings. We have the experience and know-how to assist you in making your operations both efficient and cost-effective.

Services

- Facility maintenance and HVAC/R Service Contracts
- Chiller, Boiler, AHU and all Ventilation unit PMs. maintenance and replacements
- Electrical service trouble-shooting, upgrades and installations
- Piping and Plumbing retrofits and repairs
- Sheet Metal Ducting and Roof-top upgrades and replacements
- Interstitial space (between room ceilings and next upper floor) work
- Equipment and machinery repairs, installations and relocations
- Knowledge of and abiding by Infectious Controls Disease Standards
- Turnkey Installations and Expansions
- Machinery Moving
- On-call services

Upgrades at Grand River Hospital in Kitchener, Ontario



HVAC/R Upgrades at a Public School



29 CHERRY BLOSSOM RD.
CAMBRIDGE, ON, N3H 4R7
(519) 747-2255
INFO@AIMINDUSTRIAL.CA



Ensuring the power source is enough for a packaging line addition

www.aimindustrial.ca

Packaging, Consumer Products and Chemical Plant Services

For years now, AIM Industrial's Tradespeople have been Vendors of Record helping service and maintain operations at Packaging, Consumer Products and Chemical plants. Providing labor support for multiple shifts 24/7 is a standard service of AIM Industrial. Safety standards are always maintained regardless of industry however, Chemical plants are full of special considerations, all of which AIM Industrial is well experienced with a full-time, in house Safety Group helping to facilitate and ensure people go home every day safe and sound.

Tank relocation, material transfer system installation upgrades, Piping retrofits and other improvements, along with instrumentation work and ventilation projects, are just some of the ways AIM Industrial can help out at your plant.

Services

- Sheet Metal Design, Fabrication and Installation of hoods and ducting, chutes and hopper rebuilds/replacements
- Custom catwalk/ladders/platforms for maintenance access
- Ventilation, Aspiration, and HVAC/R systems – Design/Install
- Structural repairs and Safety upgrades (guarding)
- Miscellaneous Metals
- Conveyor and material transfer system maintenance, replacement and upgrades
- Finished material, skid handling equipment maintenance
- Above ground-underground thermoplastic, stainless steel and black steel piping projects
- Electrical and mechanical trouble-shooting, rebuilds and maintenance
- Automation design and support
- Expansions and Facility upgrades
- CWB welding certification
- Project Management
- General Maintenance



Pipe and ladders installed by AIM



Check us out

www.aimindustrial.ca

Cement, Aggregate and Mining Services

AIM Industrial's skilled tradespeople have been actively involved in the cement, aggregate and mining industries for over 30 years. Our experience has come from working on hundreds if not thousands of small jobs and large projects in these particular industries. Whether it's ramping up and completing seasonal shutdowns where dozens of tradespeople from all trades come together to perform upgrades and installations, to having in house management teams on site to help plan with our customers, to going into underground mines servicing all the machinery and equipment bent in these harsh environments - we know it well.

Looking at the list below, you can see a complex assortment of projects AIM has performed. It is through this work that we are proud of the excellent reputation we have achieved within these industries. AIM Industrial is here to assist with whatever part of your company's process operations you deem fit.

Services

- Labor support for maintenance, vacations and health related times
- Sheet Metal fume extraction hoods and ducting
- Stack and Aspiration fabrication and installation
- Custom catwalk/ladders/platforms for maintenance access
- Kiln replacement and demolition, cooling system, (kiln outlet)
- Kiln lance replacement, inlet rebuild, shell demolition and inching gear maintenance
- Cooler maintenance, rebuilding, and replacements
- Rod mill rebuild, bearings, gears and wear plates
- Baghouse, heat exchanger, repairs and installations
- Fan/blower repairs and installations
- Chute and hopper rebuilds/replacements
- Conveyor installation, rebuilds and maintenance
- Structural steel and Safety Guarding
- Press Rebuild/Maintenance, brick skid handling system, fabricated/install new structure
- Bucket elevator rebuild, coal separator and conveyor systems, grizzly replacement and repairs
- Above ground-underground thermoplastic, stainless steel and black steel piping projects



Many AIM Tradespeople worked on the installation of this cement plant Stack, Baghouse, and Heat Exchanger



Ready to take away part of the kiln at a cement plant



29 CHERRY BLOSSOM RD.
CAMBRIDGE, ON, N3H 4R7
(519) 747-2255
INFO@AIMINDUSTRIAL.CA



Plant Expansion and Relocation Services

As a Multi-Trade Contractor, AIM industrial's Tradespeople and Management have over 30 years of experience with factory moves, equipment and machine relocation projects, including full turnkey factory relocations. From Tank Farms to Assembly Lines, from Heavy-duty Rigging jobs to delicate Electrical and Piping systems, from Plant Machinery Dismantling and Decommissioning, then shipping them to a new site—sometimes to a different country halfway across the world—we have the necessary experience to complete these projects safely, successfully, and on budget.

Whether it's a Brownfield or Greenfield erection and installation, AIM Industrial is well-versed in working with General Contractors, Engineering firms, Municipalities and of course, the Customer, in order to bring what was once a vision, to reality.

Services

- CWB welding
- Process and equipment installations
- Complete plant relocations
- Presses: Stamping, Injection Mold, Extruder installation, maintenance, break-down service and relocation
- Conveyor installation and modifications
- Duct and sheet metal installation
- Safety guarding fabrication, installation and modification
- Plant demolition
- Robot installation and maintenance
- Machinery moving
- Specialized and heavy rigging
- Structural reinforcing
- Steel erection
- In-plant mezzanine, catwalk, stair and handrail installation
- Specialized transport
- Machinery off-loading and placement
- Crane work
- Skidding and packaging
- Oversized fork-truck supply and operation
- PSHSR

Emerging Markets, Hydrogen and Renewable Energy

In today's world there is an ever-increasing desire to discover and create new ways of energy sources. From wind power to harnessing the sun's energy via solar panel farms or photo-voltaic cells, to new hydrogen sources or bioresins, from recycling to biomass and more, AIM Industrial has a vast experience level to assist your company's needs with the in house trades you've seen on our website.

We incorporate a highly reputable network of professional engineers, design teams, and suppliers to ensure what AIM Industrial delivers to our customers, meets or exceeds the desired end-product safely, effectively and cost efficiently. For years, AIM Industrial has been working in conjunction with General Contractors and Customers to provide you the best service possible.

Services

- Solar power, bioenergy, wind power, hydroelectric, hydrogen, recycling support, installation and repair
- Large engineered projects estimated and managed
- Sheet Metal and HVAC/R mro and project work
- Mechanical/Piping modifications, additions, complete system installation
- Electrical power upgrades, trouble-shooting and thermal imaging
- Machinery installation, commissioning, modifying and maintenance
- Shift coverage and other manpower support
- Automation support and retrofitting
- Turnkey fabrication and installation projects
- Modular building/Sea Can fabrications and modifications and installation
- Assisting customer in energy audits



Relocation of an entire Manufacturing facility in Waterloo, Ontario

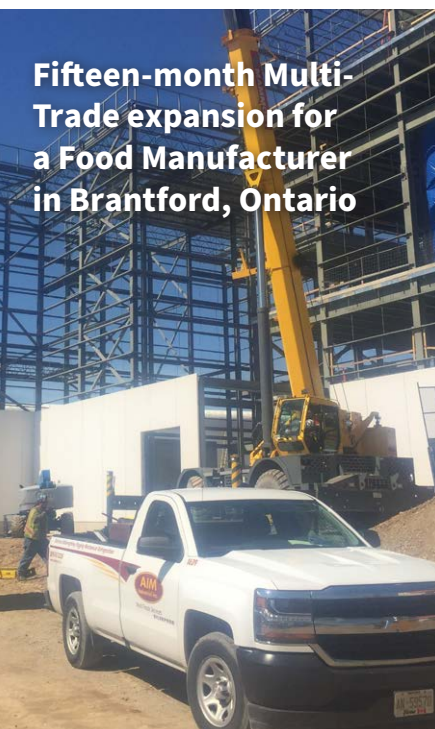

Fifteen-month Multi-Trade expansion for a Food Manufacturer in Brantford, Ontario



Final checks on a new Solar Farm install.



State-of-the-art Renewable Energy project created in our AIM Fabrication Shop



Electrical installation for green hydrogen



Check us out



29 CHERRY BLOSSOM RD.
CAMBRIDGE, ON, N3H 4R7
(519) 747-2255
INFO@AIMINDUSTRIAL.CA



AIM Industrial Trade Services

Machinery Moving and Installation

Millwrighting, Rigging and Iron Work

Electrical

Piping

Sheet Metal Fabrication and Installation

Steel Fabrication and Installation

Heating, Ventilation, Air Conditioning and Refrigeration (HVAC/R)

Modular Buildings/Pump Skids/Utility Enclosures/Power Centers

Automation, 3D Printing and Machine Shop

Robotics

Automation



Check us out

29 Cherry Blossom Rd.
Cambridge, ON, N3H 4R7

(519) 747-2255

www.aimindustrial.ca

info@aimindustrial.ca



Multi-Trade Contractor

